



Optimal Placement of Wind Farm on the Power System Topology

Nopporn Leeprechanon* and Prakornchai Phonrattanasak

Department of Electrical and Computer Engineering, Thammasat University, Pathumthani, Thailand 12120

* Corresponding Author: E-mail Lnopporn@tu.ac.th, Tel: 02 5643001-9 Ext.3050, Fax: 02 902 3948

Abstract

Wind farm can be used in domestic, community and smaller wind energy projects and these can be either stand-alone or grid-connected systems. Stand-alone systems are used to generate electricity for charging batteries to run small electrical applications, often in remote locations where it is expensive or not physically possible to connect to a mains power supply. With grid-connected turbines, the output from the wind turbine is directly connected to the existing main electricity supply. This type of system can be used both for individual wind turbines and for wind farms exporting electricity to the electricity network. A grid-connected wind turbine can be a good proposition if consumption of electricity is high. In this paper, we formulated a wind farm in form of doubly fed induction generator penetrating into an existing power system. An optimal placement of wind farm on the power system topology is proposed aiming to minimize fuel and emission costs of overall system. The multiobjective particle swarm optimization (MPSO) is used to minimize simultaneously fuel cost and emission of existing thermal units by changing location and varying sizes of new wind farm candidate. We employ IEEE 30-bus system to verify the proposed technique. The results show that the proposed method found the optimal position of wind farm with minimum cost of fuel and environmental pollution.

Keywords: Wind Farm, Power System, Multiobjective Particle Swarm Optimization (MPSO).

1. Introduction

Wind turbines produce electricity by using the natural power of the wind to drive a generator. The wind is a clean and sustainable fuel source, it does not create emissions and it will never run out as it is constantly replenished by energy from nature.

A wind farm or wind park is considered as a cluster of wind turbines that acts and is

connected to the power system as a single power producer. Generally it is expected that a wind farm consists of more than three wind turbines. Modern wind farms are installed offshore as well as on land. Size of wind turbine is selected to produce electricity energy followed by demand and wind power density. Recently, the largest wind turbine could provide electric power up to 6 MW. Modern wind farms are



generally connected to the high voltage transmission system, in contrast to the early application of wind energy for electricity production in which wind turbines individually connected to the low and medium voltage distribution system [1].

Major advantages of wind power include practical operation and friendly to the environment. Statistically worldwide, the total kinetic energy contained in wind turbine is more than 80 times that of human energy consumption. The advantage of wind power in economic sense is to save fuel with competitive operation and maintenance cost. When wind farm is installed, it is expected to produce continually electricity injecting into a power system with a small number of interruption. Moreover, wind energy system operations do not generate air or water emissions and do not produce hazardous waste. Nor do they deplete natural resources such as coal, oil, or gas, or require significant amounts of water during an operation. Wind's pollution-free electricity can help reducing the environmental damage caused by conventional power generation installed around the globe [2,3].

Recently, the Artificial Neural Network (ANN) for multi-objective optimal reactive compensation of a power system with wind generators was proposed by Lotfi Krichen et.al. [4] to find tradeoff between economic and loss in power system. However, the optimal tradeoff of economic and environment is still under development, and the problem caused by the high population of wind farm on the power system is still mysterious.

The goal of this paper is to propose a methodology to find the best location and size of wind farm in an existing power system topology with minimum fuel cost and emission of existing thermal units. The multiobjective particle swarm is developed to find minimum fuel cost and emission when the wind farm varies in its position and size. The IEEE 30-bus is selected to test the proposed technique. The results show the best location and size of wind farm with optimal fuel cost and emission in the overall system.

2. Problem Formulation

The objective of the environmental/economic power dispatch with varying of the position and size of wind farm generators is to minimize the fuel costs and environmental pollutions in generating electric power while satisfying various system constraints.

2.1 Objectives

Objective 1: Minimization of generator cost

The total fuel cost $f(P_o)$ of the overall power system in US\$/h can be expressed as

$$f(P_{Gi}, P_w) = \sum_{i=1}^N a_i + b_i P_{Gi} + c_i P_{Gi}^2 + d_i P_w \quad (1)$$

where a_i, b_i, c_i and d_i are the cost coefficients of the i^{th} existing thermal units with wind farm included. P_{Gi} and P_w are the real power output of the i^{th} thermal units and wind farm generator connected at bus w respectively. N is the number of thermal units. The set of real power output can be defined as

$$P_{Gi} = [P_{G_1}, P_{G_2}, \dots, P_{G_N}, P_w]^T \quad (2)$$

Objective 2: Minimization of environmental emission

The total ton/h emission $E(P_o)$ of atmospheric



pollutants such as sulfur oxides SO_x and nitrogen oxides NO_x caused by fossil-fueled thermal units can be expressed as

$$e(P_{Gi}, P_w) = \sum_{i=1}^N 10^{-2} (\alpha_i + \beta_i P_{Gi} + \gamma_i P_{Gi}^2) + \xi_i \exp(\lambda_i P_{Gi}) + \rho P_w \quad (3)$$

where $\alpha_i, \beta_i, \gamma_i, \xi_i, \lambda_i$ and ρ are coefficients of the i^{th} emission characteristics of thermal units and wind farm .

2.2 Constraints

Generation capacity constraints: For stable operation, real power output of each generator is restricted by lower and upper limits as follows:

$$P_{Gi}^{\min} \leq P_{Gi} \leq P_{Gi}^{\max}, \quad i = 1, \dots, N \quad (4)$$

$$P_w^{\min} \leq P_w \leq P_w^{\max}, \quad 1 \leq w \leq N_B \quad (5)$$

where N_B is the number of buses.

Power balance constraints: Power balance is an equality constraint. The total power generation must cover the total demand P_D . Hence,

$$\sum_{i=1}^N P_{Gi} + P_w - P_D - P_L = 0 \quad (6)$$

Then, power loss in transmission lines can be calculated as

$$P_{loss} = \sum_{k=1}^{N_L} g_k [V_i^2 + V_j^2 - 2V_i V_j \cos(\delta_i - \delta_j)] \quad (7)$$

where V_i and V_j are the voltage magnitudes at bus i and j . δ_i and δ_j are the voltage angles at bus i and j . g_k is the transmission line conductance. N_L is the number of transmission lines.

Line loading constraints: for securing the operation of the system can be expressed as

follows:

$$S_{Li} \leq S_{Li}^{\max}, \quad i \in N_L \quad (8)$$

where S_{Li} and N_L are transmission line loading and the number of transmission lines.

2.3 Formulation of multiobjective optimization

Aggregating the objectives and constraints, the problem can be mathematically formulated as a nonlinear constraint multiobjective optimization problem as follows [5].

$$\text{Minimize} \quad [f(x, u), e(x, u)] \quad (9)$$

Subject to:

$$g(x, u) = 0 \quad (10)$$

$$h(x, u) \leq 0 \quad (11)$$

where $g(x, u)$ is the equality constraints, $h(x, u)$ is the system inequality constraints.

3. Multiobjective optimization principles

For a multiobjective optimization problem, any two solutions x_1 and x_2 can have one or two possibilities: One dominates the other or none dominates the other. In a minimization problem, without loss of generality, a solution x_1 dominates x_2 if the following two conditions are satisfied [6]:

$$1. \forall i \in \{1, 2, \dots, N_{obj}\}: f_i(x_1) \leq f_i(x_2) \quad (12)$$

$$2. \exists i \in \{1, 2, \dots, N_{obj}\}: f_j(x_1) < f_j(x_2) \quad (13)$$

If any of the above condition is violated, the solution x_1 does not dominate the solution x_2 . If x_1 dominates the solution x_2 , x_1 is called the nondominated solution. The solutions that are nondominated within the entire search space are denoted as Pareto-optimal and constitute Pareto-optimal set. This set is also known as Pareto-optimal front.

4. THE PROPOSED MPSO TECHNIQUE

4.1 OVERVIEW OF PSO METHOD

The Particle Swarm Optimization (PSO) method is an optimization technique [7,8] which is motivated by social behaviors of organisms such as fish schooling and bird flocking. PSO provides a population-based search procedure in which individuals called "particles" change their positions (states) with time. In a PSO system, particles fly around in a multidimensional search space. During flight, each particle adjusts its position according to its own experience, and the experience of neighboring particles, making use of the best position encountered by itself and its neighbors. The swarm direction of a particle is defined by the set of particles neighboring the particle and its history experience.

4.2 Proposed MPSO and Computational process

This section describes the computational process of the proposed multiobjective particle swarm optimization (MPSO). Let x and v denote a particle coordinates (position) and its corresponding flight speed (velocity) in a search space, respectively. Therefore, the i -th particle is represented as $x_i = (P_{G1}, P_{G2}, P_{G3}, P_{G4}, P_{G5}, P_{G6}, P_w)$.

The best previous position of the i -th particle is recorded and represented as $pbest_i = (pbest_{i1}, pbest_{i2}, \dots, pbest_{id})$. The index of the best particle among all the particles in the group is represented by the $gbest_d$. The rate of the velocity for particle i is represented as $v_i = (v_{i1}, v_{i2}, \dots, v_{id})$. The computation flow of the proposed MPSO technique are briefly stated and defined as follows:

Step 1: Set iteration ($t = 1$). Generate randomly the initial particle coordinates. These initial populations must be feasible candidate solutions that satisfy the constraints.

Step 2: Run Newton power flow. Evaluate the fuel cost and emission fitness value of the initial populations.

Step 3: Search for nondominated solutions from initial solution by using nondominated function in order to get the Pareto set.

Step 4: The inertia weight is calculated according to the following equation:

$$w = w_{\max} - \frac{w_{\max} - w_{\min}}{iter_{\max}} \times iter \quad (14)$$

where $iter_{\max}$ is the maximum number of iterations and $iter$ is the current number of iterations.

Step 5: The modified velocity of each particle can be calculated using the current velocity and the distance from $pbest_{id}$ to $gbest_{id}$ as shown in the following formulas:

$$v_{id}^{t+1} = w \cdot v_{id}^t + c_1 * rand(\cdot) * (pbest_{id} - x_{id}^t) + c_2 * rand(\cdot) * (gbest_d - x_{id}^t) \quad (15)$$

where n is number of particles in a group; m is number of members in a particle; t is pointer of iterations (generations); w is inertia weight factor; c_1, c_2 are acceleration constants; $rand(\cdot)$ is uniform random value in the range $[0,1]$; v_i^t is velocity of particle i at iteration t ,

$$V_d^{\min} \leq v_{id}^t \leq V_d^{\max};$$

Step 6: The new position of particle as

$$x_{id}^{t+1} = x_{id}^t + v_{id}^{t+1}, \quad i = 1, 2, \dots, n, \quad d = 1, 2, \dots, m \quad (16)$$



where x_i^t is current position of particle at iteration t .

Step 7: Run Newton power flow. Evaluate the fuel cost and emission fitness value of the new position.

Step 8: Search for nondominated solutions from all solution by using nondominated function in order to get the Pareto set. If nondominated solution is over the limit, then uses Fuzzy C-Mean (FCM) method proposed in [10]. It will reduce the number of solution to limit.

Step 9: Check the stopping criterion. If satisfied, terminate the search, else $t = t + 1$. Go to Step 2.

Upon the Pareto-optimal set of nondominated solution, fuzzy-based mechanism is imposed to extract the best compromised outcome.

4.3 Best compromised solution

After obtaining the Pareto-optimal solution, the decision maker may need to choose one best compromised solution according to the specific preference for different applications. However, due to the inaccurate nature of human judgment, it is very often not possible to explicitly define what is really needed. Thus, fuzzy set [5] is introduced here to handle the dilemma. Here a linear membership function u_i is defined for each of the objective functions F_i :

$$u_i = \begin{cases} \frac{F_i^{\max} - F_i}{F_i^{\max} - F_i^{\min}} & F_i^{\max} > F_i > F_i^{\min} \\ 1 & F_i \leq F_i^{\min} \\ 0 & F_i \geq F_i^{\max} \end{cases} \quad (17)$$

In the above definition, F_i^{\max} and F_i^{\min} is the value of the maximum and minimum in the objective functions, respectively. It is evident that this membership function indicates the degree of achievement of the objective functions. For every nondominated solution k , the membership function can be normalized as follows:

$$u^k = \frac{\sum_{i=1}^O u_i^k}{\sum_{k=1}^S \sum_{i=1}^O u_i^k} \quad (18)$$

where O and S are the number of objective functions and the number of non-dominated solutions, respectively. The solution with the maximum membership u^k can be seen as the best compromised solution.

4.4 Implementation

The proposed MPSO technique has been developed in order to make it suitable for solving nonlinear constraints optimization problem. A computation process will check the feasibility of the candidate solution in all stages of the search process. This ensures the feasibility of the nondominated solution.

The parameter of MPSO can be set as follow. The acceleration constants c_1 and c_2 were set to be 2.0 according to past experiences. The weight w decreases linearly from about 0.9 to 0.4 during an execution. Maximum iteration = 100, then the maximum size of the Pareto-optimal set was selected as 100 solutions. The MPSO is tested to 100 runs to obtain the best solution.

4.4.1 IEEE 30-bus test system

The proposed MPSO technique was tested on IEEE 30-bus 6-generator test system. The detail data of the test system can be found in [9]. The values of fuel cost and emission coefficients are given in Table 1. The MPSO is computed by Pentium core 2 duo 2.2 GHz processor 2 GB ram under Matlab program.

Table 1. Thermal unit fuel cost and emission coefficients.

Unit	G_1	G_2	G_3	G_4	G_5	G_6
P_{\min} (MW)	50	20	15	10	10	12
P_{\max} (MW)	200	80	50	35	30	40
Cost						
a	0	0	0	0	0	0
b	2	1.75	1	1.25	3	3
c	0.00375	0.00175	0.00625	0.00834	0.02500	0.02500
Emission						
α	4.091	2.543	4.258	5.326	4.258	6.131
β	-5.554	-6.047	-5.094	-3.550	-0.5094	-5.555
γ	6.490	5.638	4.586	3.380	4.586	5.151
ξ_i	2.0E-4	5.0E-4	1.0E-6	2.0E-3	1.0E-6	1.0E-5
λ_i	2.857	3.333	8.000	2.000	8.000	6.667

4.4.2 Wind farm

A wind farm consists of a number of wind turbines connected through a power transformer to a bus (substation) of a power system. Wind turbines use a doubly-fed induction generator (DFIG) consisting of a wound rotor induction generator and an AC/DC/AC IGBT-based PWM converter. The stator winding is connected directly to the grid while the rotor is fed at variable frequency through the AC/DC/AC converter. The DFIG technology allows extracting maximum energy from the wind for low wind speeds by optimizing the turbine speed, while minimizing mechanical stresses on the turbine during gusts of wind. The

optimum turbine speed producing maximum mechanical energy for a given wind speed is proportional to the wind speed. The example of a wind farm is shown in Fig.1

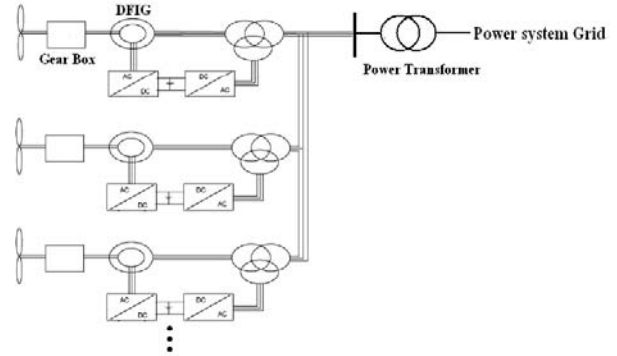

Fig.1. A wind farm with many wind turbines connected to a power system

In this paper, cost and emission coefficients of wind farm are zero. Large wind turbine is selected to produce electric power up to 1.5 MW. Minimum capacity of wind farm is set as 4.5 MW or 3 wind turbines and Maximum capacity of wind farm is set as 105 MW or 70 wind turbines. These wind turbines run at speed of wind as 12 m/s.

5. RESULTS AND DISCUSSION

Case 1: best fuel cost and emission of power system without wind farm

Fuel cost and emission objective are optimized to find the best solution by using MPSO Algorithm when the wind farm is not penetrated into the power system network. Its result is shown in Table 2.

Table 2. Best solution of the proposed approach without wind farm

Unit (MW)	Best solution
P_{G1}	114.165
P_{G2}	63.942
P_{G3}	20.289
P_{G4}	30.381
P_{G5}	28.192



P_{G6}	33.782
Total of thermal units (MW)	290.751
Fuel Cost(\$/h)	847.430
Emission(ton/hr)	0.245

Case 2: best fuel cost and emission of power system with wind farm penetration

Wind farm is penetrated into IEEE 30-bus test system. Its result can be shown in Table 3. and Fig 2.

Table 3. Results of best solution of the proposed approach with wind farm on IEEE 30-bus test system

Unit (MW)	Best solution with wind farm
P_{G1}	48.454
P_{G2}	34.443
P_{G3}	30.439
P_{G4}	29.079
P_{G5}	16.122
P_{G6}	28.612
Total of thermal units (MW)	187.149
Fuel Cost(\$/h)	541.52
Emission(ton/hr)	0.209
<i>Wind farm</i>	
Location (Bus)	7
Size (MW)	99.73

Table 3 shows the power generation and wind farm position optimized by the MPSO technique. The result in this case produces cost and emission lower than previous case. Wind farm which is penetrated into IEEE 30-bus test system can reduce fuel cost and emission of pollution as 305.91 \$/h and 0.036 ton/h respectively.

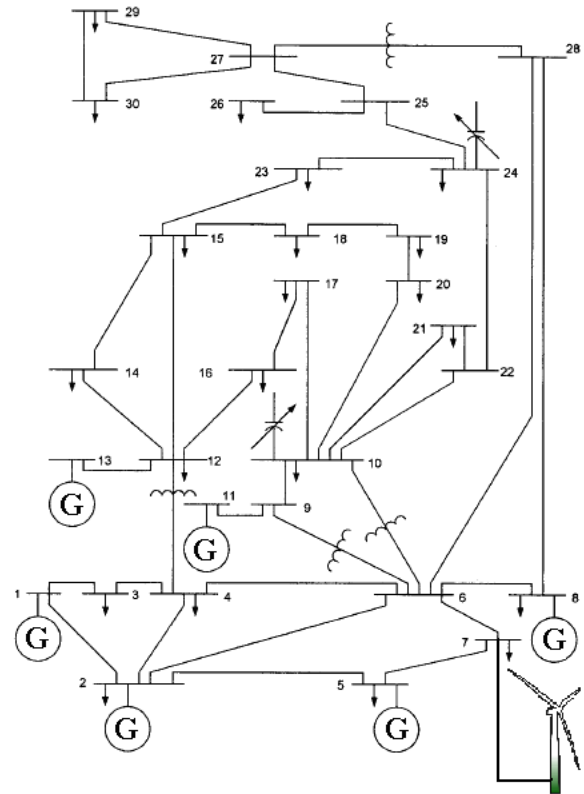

Fig.2 optimal position of wind farm on a power system

Wind farm is connected to power system at bus 7 in Fig 2. Capacity of wind farm is 99.73 MW or approximately 66 wind turbines. The result shows a high penetration of wind farm on the test system.

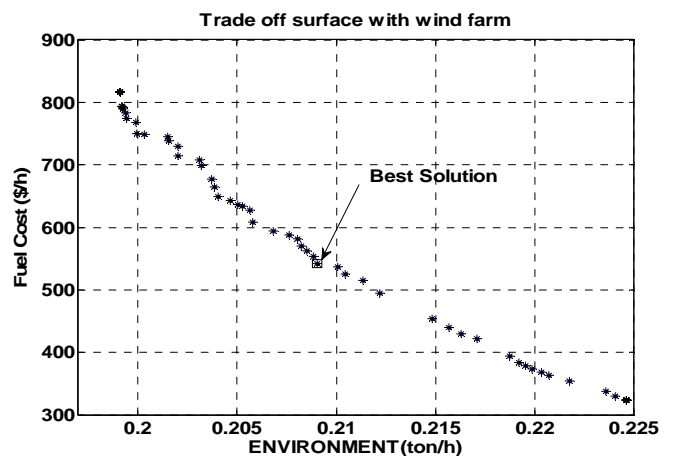

Fig.3 Best solution on tradeoff surface with wind farm in power system

The best solution in tradeoff surface is selected by fuzzy compromise method in Fig 3.

7. Conclusion

This paper proposes MPSO algorithm to find best location and size of a wind farm penetrating to a power system topology with optimal fuel cost and environmental emission of generations. A wind farm is formulated in form of doubly fed induction generators to inject electric power into the power system. The simulation results demonstrate that a wind farm with optimum size and location can reduce fuel cost and emission pollutant of generators. In addition, the results confirm that the MPSO algorithm has effectiveness to search optimum position and size of wind farm on a power system topology.

8. Reference

- [1] Z. Chen, F. Blaabjerg, Wind farm--A power source in future power systems, *Renewable and Sustainable Energy Reviews*, Volume 13, Issues 6-7, Pp.1288-1300, August-September 2009
- [2] Chyou-Jong Lin, Oliver S. Yu, Chung-Liang Chang, Yuin-Hong Liu, Yuh-Fa Chuang, Yu-Liang Lin, Challenges of wind farms connection to future power systems in Taiwan, *Renewable Energy*, Volume 34, Issue 8, 2007
- [3] R. Saidur, M.R. Islam, N.A. Rahim, K.H. Solangi, A review on global wind energy policy, *Renewable and Sustainable Energy Reviews*, Volume 14, Issue 7 Pp. 1744-1762, September 2010.
- [4] Lotfi Krichen, Housseem Ben Aribia, Hsan Hadj Abdallah, Abderrazak Ouali, ANN for multi-objective optimal reactive compensation of a power system with wind generators, *Electric Power Systems Research*, Volume 78, Issue 9, Pp. 1511-1519, September 2008.
- [5] Abido, M.A. "Multiobjective particle swarm optimization for environmental/economic dispatch problem." *Electric Power Systems Research* 79(7), Pp. 1105-1113, 2009.
- [6] Tahir Sag, Mehmet Cunkas, A tool for multiobjective evolutionary algorithms, *Advances in Engineering Software*, Volume 40, Issue 9, Pp. 902-912, September 2009.
- [7] J. Kennedy and R. Eberhart, "Particle swarm optimization", *Proceeding of the 4th IEEE International Conference on Neural Networks*, Pp. 1942-1948, 1995.
- [8] M. A. Abido, Optimal power flow using particle swarm optimization, *International Journal of Electrical Power & Energy Systems*, Volume 24, Issue 7, Pp. 563-571, October 2002.
- [9] Alsac, O.; Stott, B.; , "Optimal Load Flow with Steady-State Security," *Power Apparatus and Systems, IEEE Transactions on* , vol.PAS-93, no.3, Pp.745-751, May 1974.
- [10] Mendoza, F.; Bernal-Agustin, J.L.; Dominguez-Navarro, J.A., "NSGA and SPEA Applied to Multiobjective Design of Power Distribution Systems," *Power Systems, IEEE Transactions on*, vol.21, no.4, Pp.1938-1945, Nov. 2006.